

In questo libro troverai tre robot originali creati da Roberto Stelzer, designer brasiliano.  
Per ciascuno, Roberto ti propone una versione in bianco da colorare  
e una già colorata che potrai comunque personalizzare con gli sticker inclusi.

**R0DOT**



**LUNETIC**



**ER4<sup>8</sup>**

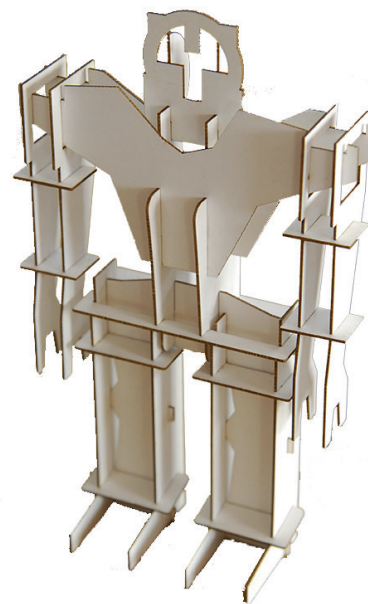

## CONSIGLI DI MONTAGGIO

Stacca gli elementi in ordine e assemblali come indicato  
nel disegno qua sotto per **R0DOT** e nell'ultima pagina per **LUNETIC** e **ER4<sup>8</sup>**.

**R0DOT**

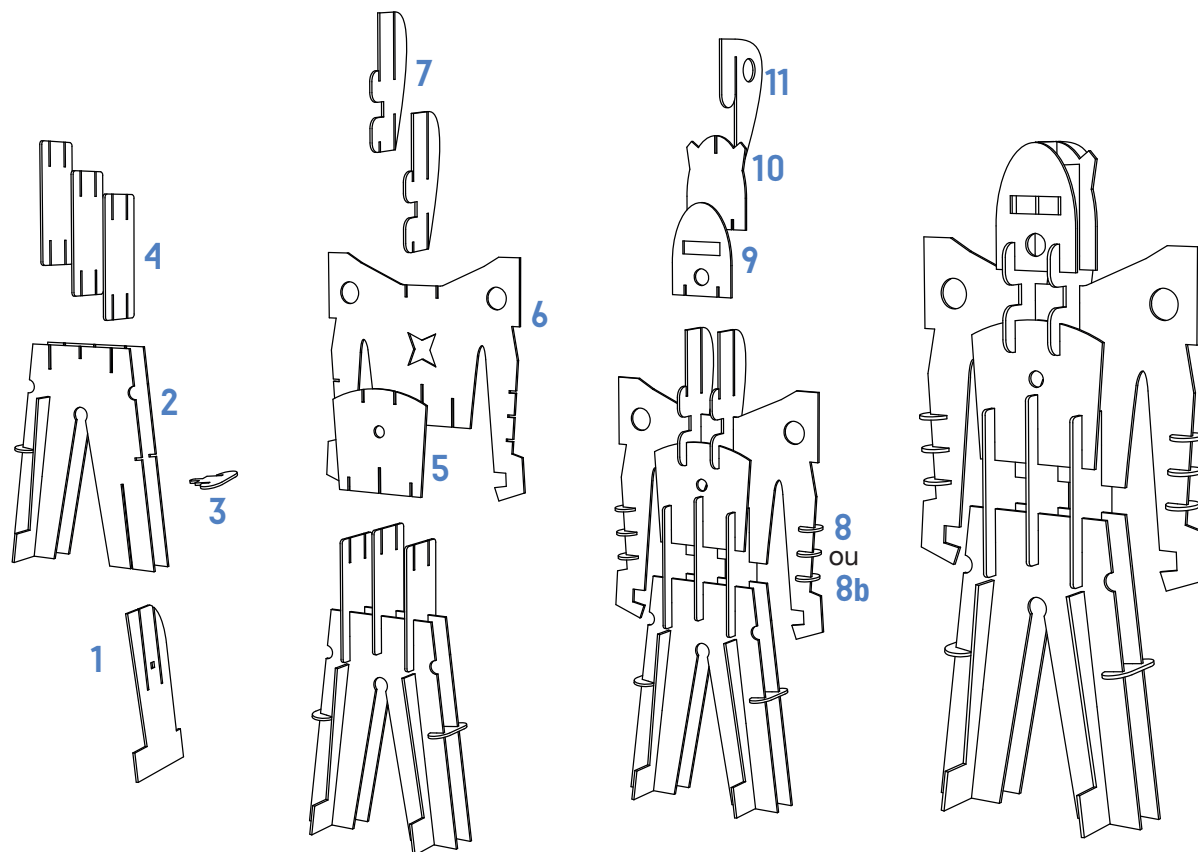
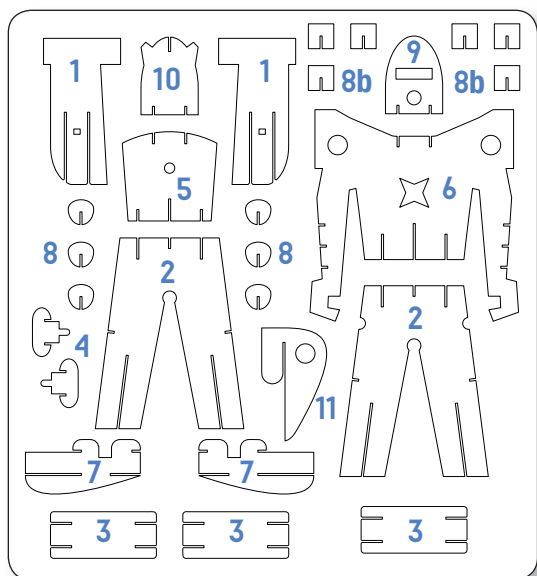

# LUNETIC

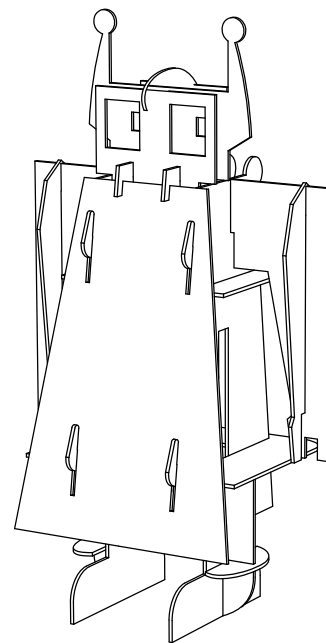
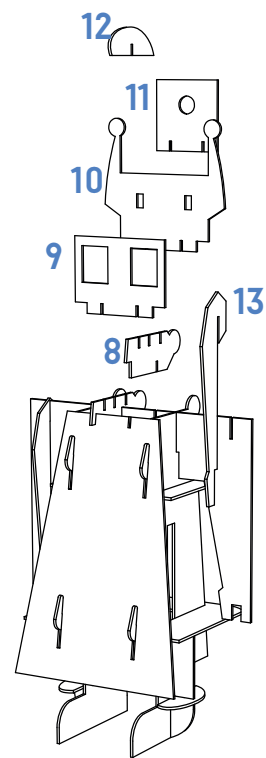
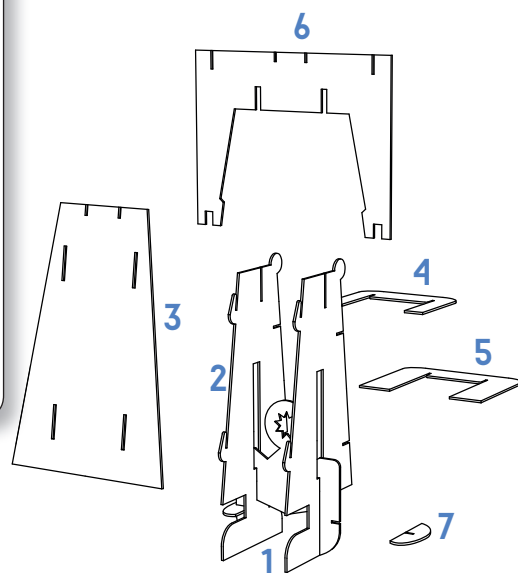
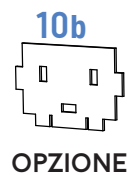
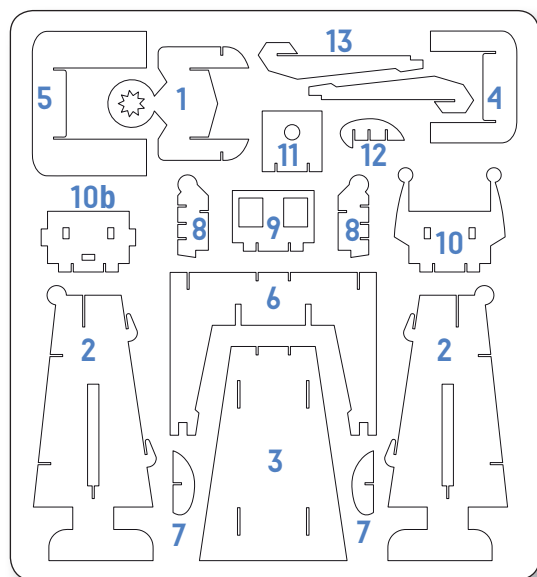

# ER4<sup>8</sup>

